

ZONE	REV	DESCRIPTION	DATE	REVISED BY	APPROVED BY
------	-----	-------------	------	------------	-------------

AIR MOTOR DETAILS

Maximum RPM = 3000
 Maximum Pressure = 100 psi
 Horsepower = 1.2 @ 40 in/lb torque / 90 psi
 Maximum Air Consumption = 78 CFM
 Mounting Restrictions = None
 Rotation = Reversible
 Fitting Size = 1/4" NPT Inlet / 1/4" NPT Exhaust

GEAR BOX DETAILS

Gear Reduction = 4.3 : 1
 Nominal Output RPM = 400
 Mounting Restrictions = None
 Rotation = Reversible

LUBRICATION & AIR SUPPLY

Proper operation of the air motor attached to this drive requires that the motor be lubricated. AMI recommends the use of a positive displacement single point lubricator.
 Use a high quality hydraulic or SAE automotive engine oil with anti-wear, anti-oxidation, VI improver, rust inhibitor, and detergent additives. Viscosity should be approximately 220 SUS or SAE #10. Pre-filter lubricating fluid to ISD 4406 (SAE J165) 18/16/14.
 Air supplied to the motor must be clean and dry (no moisture). AMI recommends the use of a non-clogging separator with a minimum of a 40-micron filter downstream of the regulator. Additionally, the use of a 3-micron coalescing filter with Dioctyl Phthalate (DOPP) efficiency of 99.97% should be mounted downstream of the pre-filter.

Exhausted air must comply with OSHA regulation 29CFR, Part 1910, Sub-Part Z, Section 1910.1000, and Table Z1 for air contaminants. (TLV-TWA) User must also comply with the OSHA sound level requirements of 29CFR, Section 1910.95. The use of reclassifiers is indicated.

USE OF AIR MOTORS IN HAZARDOUS ATMOSPHERES

At the time of this writing, there are no known standards for the operation of air motors in hazardous atmospheres. However, there are several points to remember regarding their operation.
 First, an air motor is not a source of electric sparks. It is possible, however, that an article which is not part of the air motor, such as wrenches, could create a spark if sharply impacted on the cast iron or aluminum components, or the shaft of the air motor.
 Second, an air motor housing is not designed to contain an internal explosion as is an explosion-proof electric motor. The only possible internal source of ignition in an air motor is a contact between the stationary housing components and the rotating elements creating a spark. The likelihood of this occurring is reduced by the fact that the contact must be made at precisely the same time as a flammable or explosive atmosphere is introduced into the air motor in a sufficient quantity to achieve a flammable or explosive mixture while overcoming the positive pressure of the driving gas.
 Finally, an air motor is designed to operated by compressed air, the expansion of which in normal operation creates a cooling effect. As a result, the temperature of the air motor will not exceed the higher of the temperatures of the surrounding atmosphere or the air delivered to the inlet.
 We do not guarantee the safety of every application, but to ensure the safe operation of an air motor in your application, always follow the product directions and consult with a qualified engineer.
WARNING: Units should not be propelled by combustible gasses.

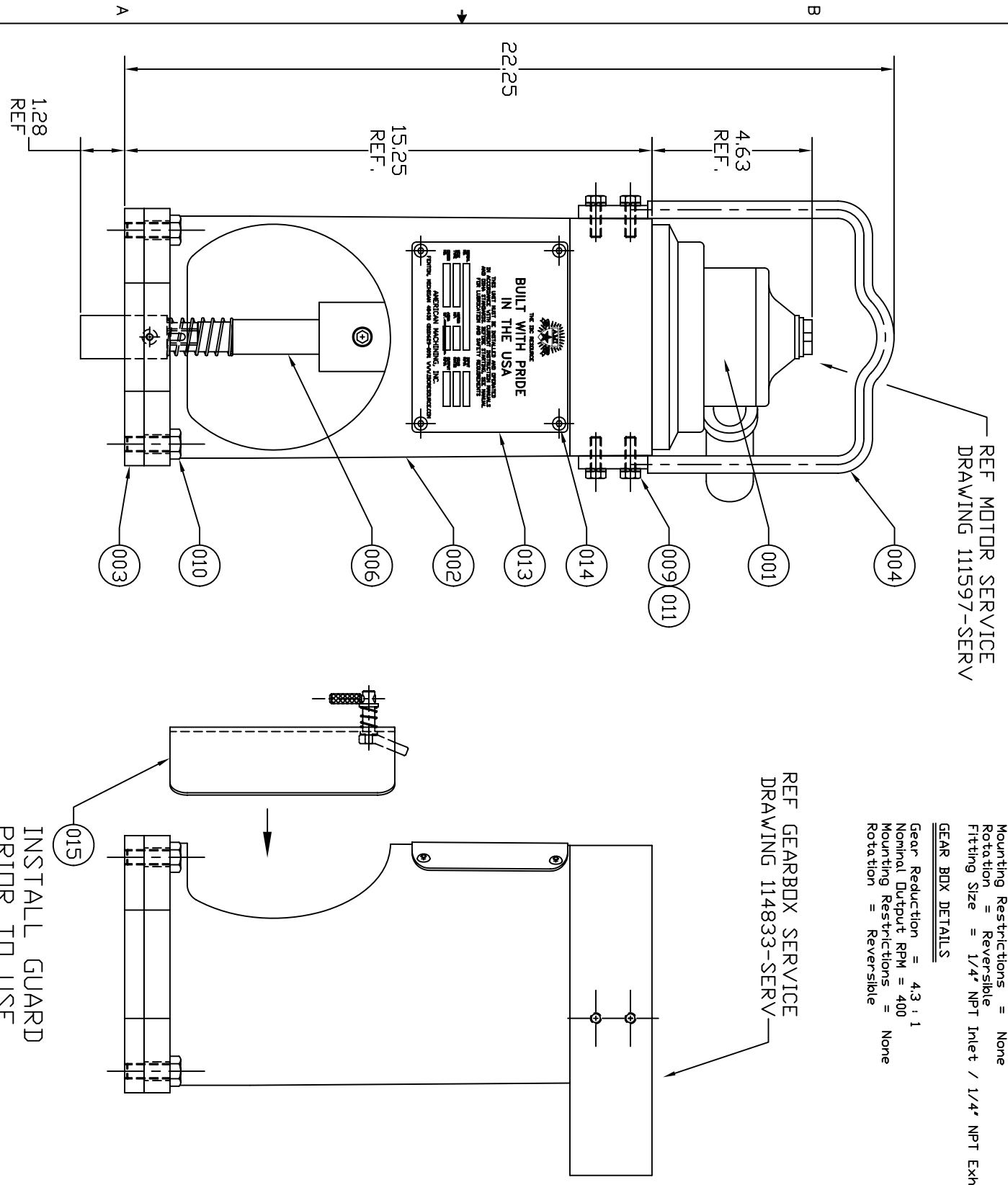

DETAIL	QTY.	PART NO.	DESCRIPTION
001	1	111597	MOTOR - 1 HP AIR
002	1	114833	GEARBOX
003	1	112859	FLANGE - DRIVE ADAPTER / QUICK CONNECT BASE
004	1	112974	HANDLE - 1/2" DIA HVY DUTY LIFTING
005	---	---	---
006	1	113981	ADAPTER - HEX SHAFT ASSEMBLY
007	---	---	---
008	---	---	---
009	4	112975	SCREW - HHCS ZINC PLT
010	4	112867	SCREW - HHCS GR 8 ZINC PLT
011	4	112755	WASHER - SPLIT LOCK ZINC PLT
012	---	---	---
013	1	111645	TAG - AMI ID 304 SS
014	4	112972	SCREW - BUTTON HD CAP 18-8 SS
015	1	114090	GUARD - DRIVE MOTOR ASSY

UNLESS OTHERWISE SPECIFIED DIMENSIONS ARE IN INCHES GENERAL TOLERANCES	FRACTIONS: ± 1/4	DECIMALS: ± .12	DECIMALS: ± .06	DECIMALS: ± .015	ANGLES: ± 2°
--	------------------	-----------------	-----------------	------------------	--------------

THIS DRAWING HAS BEEN FURNISHED BY AMERICAN MACHINING, INC. THE INFORMATION AND KNOW-HOW CONTAINED MAY NOT BE USED NOR MAY THE DRAWING BE REPRODUCED WITHOUT THE WRITTEN PERMISSION OF AMERICAN MACHINING, INC. ALL REPRODUCTIONS IN WHOLE OR IN PART, INCLUDING VENDOR SHOP DRAWINGS, SHALL BEAR OR REFER TO THIS NOTE.

PRODUCTION: DO NOT SCALE THIS DRAWING. BREAK SHARP EDGES. REMOVE BURRS & FLASH.

FINISH: N/A

SPECIAL FINISH: N/A

DRAWN BY: SCHULTE
 CHECKED BY: REICH
 DATE: 12/16/03

SCALE: NONE
 MAT'L: N/A

DESCRIPTION: DRIVE - 1 HP AIR W/ HEX OUTPUT CONNECTION

PART NUMBER: 112838-SERV

REV: H

APPROVED BY: DATE: SHEET 1 OF 1