

BUNG LOCATION

OUTLET VALVE LOCATION

**LEGEND**

- REPLACE EVERY REPAIR
- MIN. OF 2 TURNS OR REPLACE IF DAMAGED
- MIN. OF 3 TURNS OR REPLACE IF DAMAGED
- REPLACE ONLY IF DAMAGED

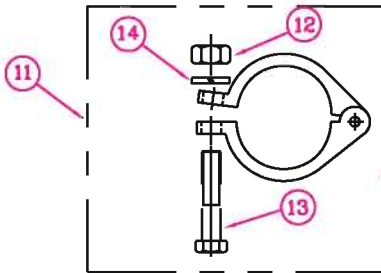
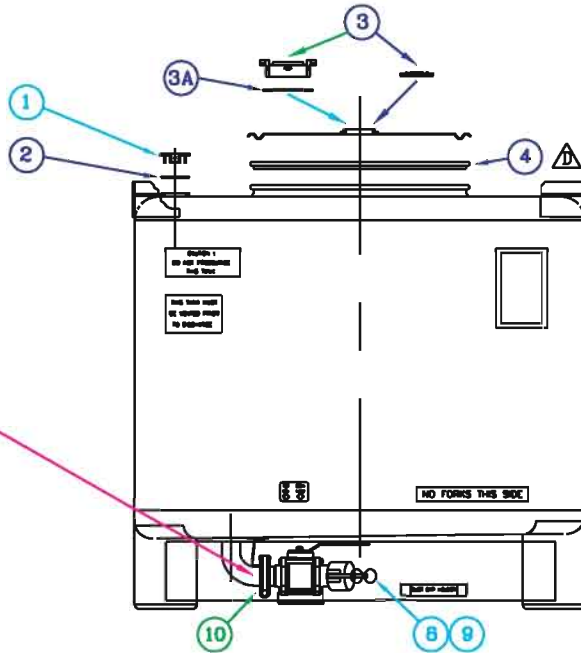
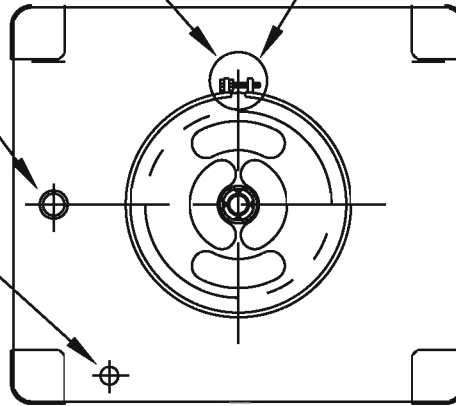

--	E	DET. #8 REMOVED WAS 110029 / DET. #9 WAS 111334	25-MAR-04	REICH	G.P.S.
--	D	DET. #7 WAS 110587 / DET. #4 WAS 110819-B	22-APR-03	M.C.S.	REICH
--	C	ADDED DET. 3A	26-SEP-02	M.C.S.	REICH
--	B	DET 12 WAS 110613, DET 13 WAS 2.5"	26-MAR-02	REICH	G.P.S.
--	B	DET 1 WAS 110885, DET 2 WAS 110615, DET4 WAS 110819, DET 9 WAS 111257	26-MAR-02	REICH	G.P.S.
--	A	DET. 5 WAS 110878 & 110572, DET. 12 WAS 110613, ADDED DET. 14	11-MAR-02	REICH	G.P.S.
ZONE	REV	REVISION DESCRIPTION	DATE	REVISED BY	APPROVED BY

UNLESS OTHERWISE SPECIFIED  
DIMENSIONS ARE IN INCHES  
GENERAL TOLERANCES



DO NOT SCALE THIS DRAWING  
BREAK ALL SHARP EDGES  
REMOVE BURRS & FLASH



**AMERICAN MACHINING, INC.**  
FENTON, MICHIGAN

FRACTIONS:	.XX DECIMALS: ± 1/32	.XXX DECIMALS: ± .010	.XXXX DECIMALS: ± .005	ANGLES: ± 1°
------------	----------------------------	-----------------------------	------------------------------	-----------------

FINISH:	N/A ✓
SPECIAL FINISH:	N/A
DRAWN BY:	M. SCHULTE
CHECKED BY:	
DATE:	26-SEP-02
APPROVED BY:	

DESCRIPTION		
PORTABLE TANK SERVICE PARTS INFORMATION		
SIZE	PART NUMBER	REV
A	114233	E
SCALE: NONE	MAT'L: N/A	SHEET 1 OF 2

THIS DRAWING HAS BEEN FURNISHED BY AMERICAN MACHINING, INC. THE INFORMATION AND KNOW-HOW CONTAINED MAY NOT BE USED NOR MAY THE DRAWING BE REPRODUCED WITHOUT THE WRITTEN PERMISSION OF AMERICAN MACHINING, INC. ALL REPRODUCTIONS IN WHOLE OR IN PART, INCLUDING VENDOR SHOP DRAWINGS, SHALL BEAR OR REFER TO THIS NOTE.

**SERVICE PARTS INFORMATION**

ITEM	QTY.	DESCRIPTION	MAT'L.	AMI PART #
1	1	SAFBUNG - ELECTROPOLISHED	316 SS	110885-B
2	1	GASKET - BUNG, .19 THK	EPDM	113843
3	1	PLUG - POLYGRIP FUSIBLE VENT WITH CRIMP RING	HDPE/SS	110847 *
		FUZVENT - 3" NPS, FUSIBLE VENT	HDPE	111726 *
⚠ 3A	1	GASKET - FOR FUZVENT	EPDM	113847 *
⚠ 4	1	GASKET - DRUM TOP CHIME	EPDM	114324
5	1	RING - CLAMP, RELIEVED ENDS	304 SS	113842 **
6	1	SCREW - 5/8-11 x 5.00 HEX HEAD CAP	ZINC PLATED	110878
⚠ 7	1	NUT - 5/8-11 HEX FINISHED JAM GR-2	ZINC PLATED	114510
⚠ 8	--	-----	---	---
⚠ 9	1	CAP - DUST, 2" KAMLOCK WITH STRAIGHT ARMS	316 SS	111257-B
10	1	GASKET - SANITARY CONNECTION	TFE	110599
11	1	CLAMP ASSEMBLY - 2" I-LINE (INCL SS SCREW & NYLOCK NUT)	316 S/S	110651
12	1	NUT - 1/2-13 HEX, GR-2	ZINC PLATED	110585
⚠ 13	1	SCREW - 1/2-13 x 2" LG. HHCS, GR-5	ZINC PLATED	111601
14	1	WASHER - 1/2 SPLIT LOCK	ZINC PLATED	110617



\* DEPENDENT ON COVER ASSEMBLY

\*\* 113842 IS PREFERRED COMPONENT, 111410-B IS OPTIONAL FOR URGENT SITUATION ONLY

**LEGEND**

- REPLACE EVERY REPAIR
- MIN. OF 2 TURNS OR REPLACE IF DAMAGED
- MIN. OF 3 TURNS OR REPLACE IF DAMAGED
- REPLACE ONLY IF DAMAGED

--	E	DET. #8 REMOVED WAS 110029 / DET. #9 WAS 111334	25-MAR-04	REICH	G.P.S.
--	D	DET. #7 WAS 110587 / DET. #4 WAS 110819-B	22-APR-03	M.C.S.	REICH
--	C	ADDED DET. 3A	26-SEP-02	M.C.S.	REICH
--	B	DET 12 WAS 110613, DET 13 WAS 2.5"	26-MAR-02	REICH	G.P.S.
--	B	DET 1 WAS 110885, DET 2 WAS 110615, DET4 WAS 110819, DET 9 WAS 111257	26-MAR-02	REICH	G.P.S.
--	A	DET. 5 WAS 110878 & 110572, DET. 12 WAS 110613, ADDED DET. 14	11-MAR-02	REICH	G.P.S.
ZONE	REV	REVISION DESCRIPTION	DATE	REVISED BY	APPROVED BY

UNLESS OTHERWISE SPECIFIED DIMENSIONS ARE IN INCHES GENERAL TOLERANCES		PROJECTION 	DO NOT SCALE THIS DRAWING BREAK ALL SHARP EDGES REMOVE BURRS & FLASH		<b>AMERICAN MACHINING, INC.</b> FENTON, MICHIGAN	
FRACTIONS: ± 1/32	.XX DECIMALS: ± .010	.XXX DECIMALS: ± .005	.XXXX DECIMALS: ± .001	ANGLES: ± 1°	FINISH: N/A ✓	
THIS DRAWING HAS BEEN FURNISHED BY AMERICAN MACHINING, INC. THE INFORMATION AND KNOW-HOW CONTAINED MAY NOT BE USED NOR MAY THE DRAWING BE REPRODUCED WITHOUT THE WRITTEN PERMISSION OF AMERICAN MACHINING, INC. ALL REPRODUCTIONS IN WHOLE OR IN PART, INCLUDING VENDOR SHOP DRAWINGS, SHALL BEAR OR REFER TO THIS NOTE.				DESCRIPTION <b>PORTABLE TANK SERVICE PARTS INFORMATION</b>		
				DRAWN BY: M. SCHULTE	26-SEP-02	SIZE <b>A</b>
APPROVED BY: _____		DATE _____		SCALE: NONE	MAT'L: N/A	SHEET 2 OF 2

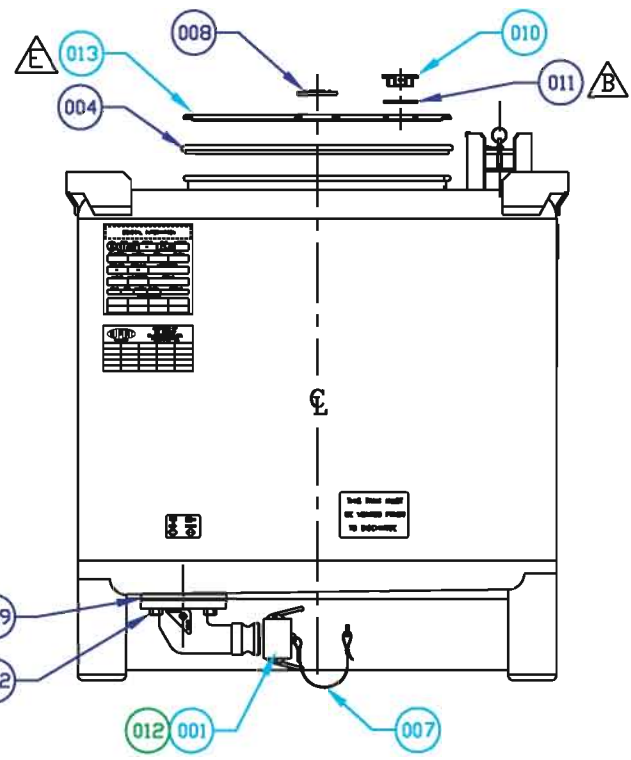
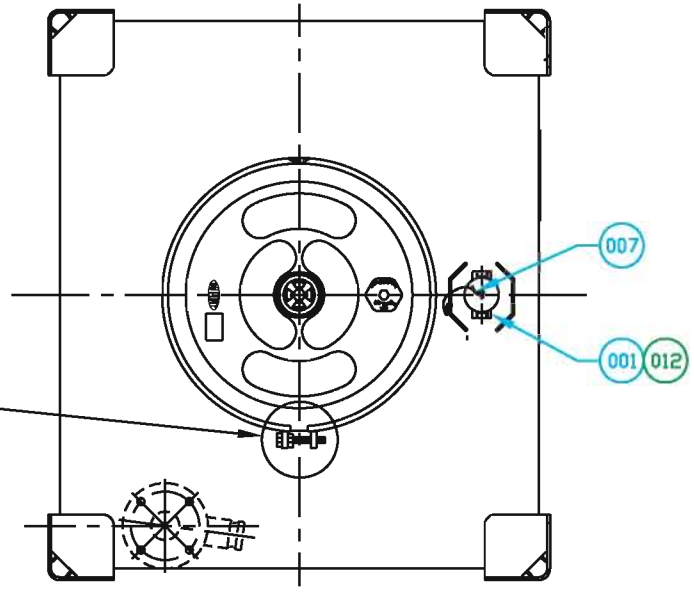
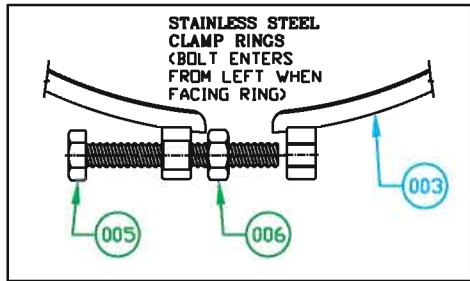

- Replace every repair
- Min. 2 turns or replace if damaged
- Min. 3 turns or replace if damaged
- Replace only if damaged
- Not applicable

ZONE	REV	REVISION DESCRIPTION	DATE	REVISED BY	APPROVED BY
-	E	ADDED DET. # 013	06-08-2004	REICH	GPS
-	D	DET. # 007 DESCRIPTION WAS "MANUFACTURED"	05-24-2004	REICH	GPS
-	C	DET. # 012 DESCRIPTION WAS "MANUFACTURED"	05-20-2004	REICH	GPS
-	B	DET. # 011 WAS 110615	05-05-04	WJF	B.R.
-	A	ADDED COMPONENT TYPE COLUMN	04-05-04	M.C.S.	B.R.

UNLESS OTHERWISE SPECIFIED DIMENSIONS ARE IN INCHES GENERAL TOLERANCES		PROJECTION 	DO NOT SCALE THIS DRAWING BREAK ALL SHARP EDGES REMOVE BURRS & FLASH	AMERICAN MACHINING, INC. FENTON, MICHIGAN
FRACTIONS: ± 1/32	.XX DECIMALS: ± .010	.XXX DECIMALS: ± .005	.XXXX DECIMALS: ± .001	ANGLES: ± 1°
THIS DRAWING HAS BEEN FURNISHED BY AMERICAN MACHINING, INC. THE INFORMATION AND KNOW-HOW CONTAINED MAY NOT BE USED NOR MAY THE DRAWING BE REPRODUCED WITHOUT THE WRITTEN PERMISSION OF AMERICAN MACHINING, INC. ALL REPRODUCTIONS IN WHOLE OR IN PART, INCLUDING VENDOR SHOP DRAWINGS, SHALL BEAR OR REFER TO THIS NOTE.		FINISH: N/A ✓	SPECIAL FINISH: N/A	DESCRIPTION PORTABLE TANK SERVICE PARTS INFORMATION
DRAWN BY: M. SCHULTE CHECKED BY: B. REICH		05-19-03 04-06-04	APPROVED BY: _____ DATE _____	SIZE A
SCALE: NONE		MAT'L: N/A		PART NUMBER 114525
SHEET 1 OF 2		REV E		



ITEM NO.	PART NUMBER	QTY.	DESCRIPTION	TURNS
001	111257	2	CAP - 2" DUST 316 SS W/STRAIGHT ARMS	
002	110588	4	NUT- 5/8-11 HEX FINISH NYLOC ZINC PLATED	
003	113842	1	RING - CLAMP ASSY 304 SS ELECTROPOLISHED	
004	114324	1	GASKET - BLACK	
005	110676	1	BOLT - 5/8-11 X 5" LG BTA GR-5 ZINC PLT	
006	114510	1	NUT - 5/8-11 HEX FINISHED JAM GR-2 ZINC PLT	
007	110029	2	LANYARD - 13" LG ASSEMBLY	
008	110647	1	PLUG - 2" RIEKE POLY GRIP FUSIBLE VENT	
009	-----	1	GASKET - VALVE DEPENDENT	
010	110885	1	SAFBUNG - 2" NPS ELECTROPOLISHED 316L SS	
011	113843	1	GASKET - 2" BUNG WHITE	
012	110717	1	GASKET - DUST CAP WHITE	
013	110467	1	COVER - 16 GA ASSY (INCLUDES DET. #008, 010, & 011)	



	Replace every repair
	Min. 2 turns or replace if damaged
	Min. 3 turns or replace if damaged
	Replace only if damaged
	Not applicable

-	E	ADDED DET. # 013	06-08-2004	REICH	GPS
-	D	DET. # 007 DESCRIPTION WAS "MANUFACTURED"	05-24-2004	REICH	GPS
-	C	DET. # 012 DESCRIPTION WAS "MANUFACTURED"	05-20-2004	REICH	GPS
-	B	DET. # 011 WAS 110615	05-05-04	WJF	B.R.
-	A	ADDED COMPONENT TYPE COLUMN	04-05-04	M.C.S.	B.R.
ZONE	REV	REVISION DESCRIPTION	DATE	REVISED BY	APPROVED BY

UNLESS OTHERWISE SPECIFIED DIMENSIONS ARE IN INCHES GENERAL TOLERANCES			DO NOT SCALE THIS DRAWING BREAK ALL SHARP EDGES REMOVE BURRS & FLASH		<b>AMERICAN MACHINING, INC.</b> FENTON, MICHIGAN		
FRACTIONS: ± 1/32 DECIMALS: ± .010 .XX DECIMALS: ± .005 .XXX DECIMALS: ± .001 .XXXX DECIMALS: ± 1° ANGLES:	FINISH: N/A ✓ SPECIAL FINISH: N/A		DESCRIPTION <b>PORTABLE TANK          SERVICE PARTS INFORMATION</b>				
THIS DRAWING HAS BEEN FURNISHED BY AMERICAN MACHINING, INC. THE INFORMATION AND KNOW-HOW CONTAINED MAY NOT BE USED NOR MAY THE DRAWING BE REPRODUCED WITHOUT THE WRITTEN PERMISSION OF AMERICAN MACHINING, INC. ALL REPRODUCTIONS IN WHOLE OR IN PART, INCLUDING VENDOR SHOP DRAWINGS, SHALL BEAR OR REFER TO THIS NOTE.			DRAWN BY: <b>M. SCHULTE</b> CHECKED BY: <b>B. REICH</b>	05-19-03 04-06-04	SIZE <b>A</b>	PART NUMBER <b>114525</b>	REV <b>E</b>
APPROVED BY: _____ DATE _____			SCALE: <b>NONE</b> MAT'L: <b>N/A</b>		SHEET <b>2</b> OF <b>2</b>		