



**American Machining, Incorporated
Fenton, Michigan**

AMS-006

**CAM SEAL AGITATOR COVER
LOCKING/UNLOCKING INSTRUCTIONS**

Issued: March 20, 2001
Revised: October 08, 2003



TABLE OF CONTENTS

1 SCOPE	3
2 RECOMMENDED TOOLS	3
3 LOCKING FOR TRANSPORTATION	3
4 UNLOCKING FOR AGITATION	3
5 ANNEX "A"	5-7



1 Scope

1.1 The intent of this document is to establish the locking for transportation and unlocking for agitation procedures for Cam Seal agitator covers supplied by American Machining, Incorporated. It is issued to direct this and customer facilities in obtaining and maintaining reliable operation and sealing of intermediate bulk container (IBC) systems. In the development of this specification, utmost priority was given to the enhancement of safety in the operation and maintenance of these containers in conjunction with compliance to Federal, State, and municipal regulation and safety codes. All personnel servicing intermediate bulk containers must comply with the most recent revision of the following specifications:

- 1.1.1 U.S. Title 49 CFR Parts 178-180
- 1.1.2 U.S. Title 49 CFR Parts 350-399
- 1.1.3 U.S. Title 49 CFR Parts 40.1910-1200
- 1.1.4 U.S. Title 49 CFR Parts 100-177
- 1.1.5 U.S. Title 29 CFR (OSHA)
- 1.1.6 MIOSHA, where applicable
- 1.1.7 CALOSHA, where applicable
- 1.1.8 NFPA, where applicable
- 1.1.9 NEC, where applicable
- 1.1.10 Industry consensus standards, e.g. ANSI, etc., where applicable

Note that the above specifications may require compliance to other specifications not listed

1.2 In addition to the above standards, the specifications contained in this document shall apply. Where similar specifications exist, the most stringent specification shall be utilized.

1.3 It is imperative that service personnel be familiar with proper safety procedures when using small hand tools.

1.4 Read all instructions prior to proceeding.

2 Recommended Tools

2.1 It is recommended that the following tools are available for proper service:

- 2.1.1 Coupling Wrench, American Machining part number 114787

3 Locking for Transportation

3.1 Refer to drawing Annex "A"

3.1.1 Note: Never transport containers or agitator covers without first locking the shaft/coupling assembly into the transport position.

3.1.2 Align scallops in coupling with retainer pins, allowing coupling to rest flush with cover flange. (see fig. 1)

3.1.3 Rotate coupling by hand in a clockwise direction (allowing retainer pins to engage locking ramps) until snug.

3.1.4 Install coupling wrench (AMI p/n 114787) over coupling dogs until flush with coupling surface. (see fig. 2)

3.1.5 Using coupling wrench, rotate coupling until locking pin engages hole in flange. An audible click will be heard. (see fig. 3)
CAUTION! Do not rotate coupling past point where locking pin engages hole in flange. Pin or coupling may be damaged which could affect the sealing integrity of the container. Cycle locking pin up and down several times to ensure that pin is not constrained by over-rotation of the coupling. Rotate coupling counter-clockwise slightly if needed.

3.1.6 Agitator shaft is now locked in place, ready for transport.

4 To Unlock Agitator Shaft

4.1 Refer to drawing Annex "A"

4.1.1 Install coupling wrench (AMI p/n 114787) over coupling dogs until flush with coupling surface. (see fig. 2)

4.1.2 Lift locking pin to disengage pin from hole in flange. Pin travel is approximately 1/8". (see fig. 1)

4.1.3 While maintaining pin in the raised position, rotate coupling counter-clockwise approximately 1/16 turn (22°) to allow locking pin to clear hole in flange, then



AMS-006 CAM SEAL INSTRUCTIONS

release pin. (see fig. 3)

CAUTION! Release pin immediately after pin clears flange hole to avoid any potential pinch hazard.

- 4.1.4 Continue rotating coupling in counter-clockwise direction until retainer pins are aligned with scallops in coupling.
- 4.1.5 Shaft may then be raised to the mixing position.



5 ANNEX A (Drawings)

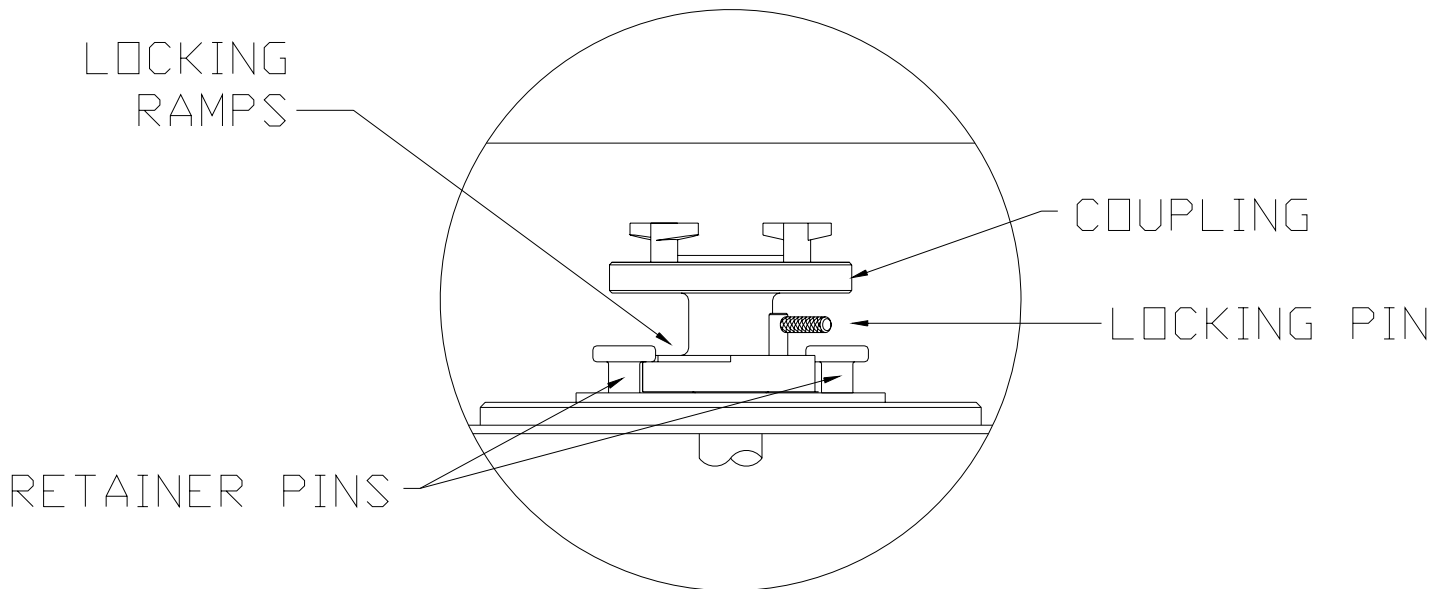
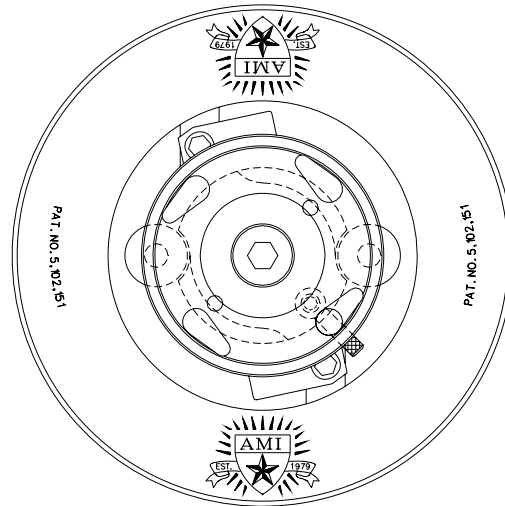

FIGURE 1

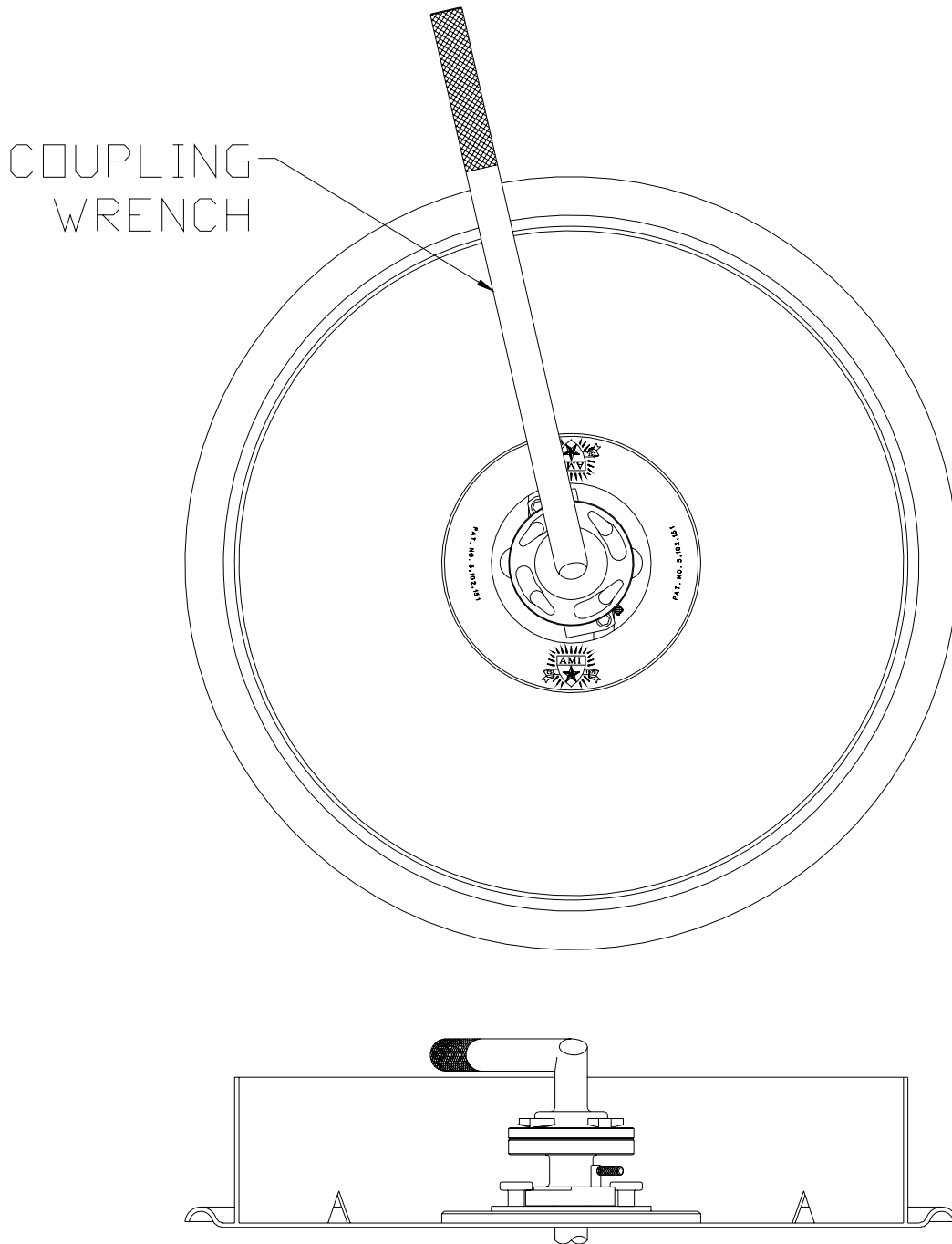

FIGURE 2

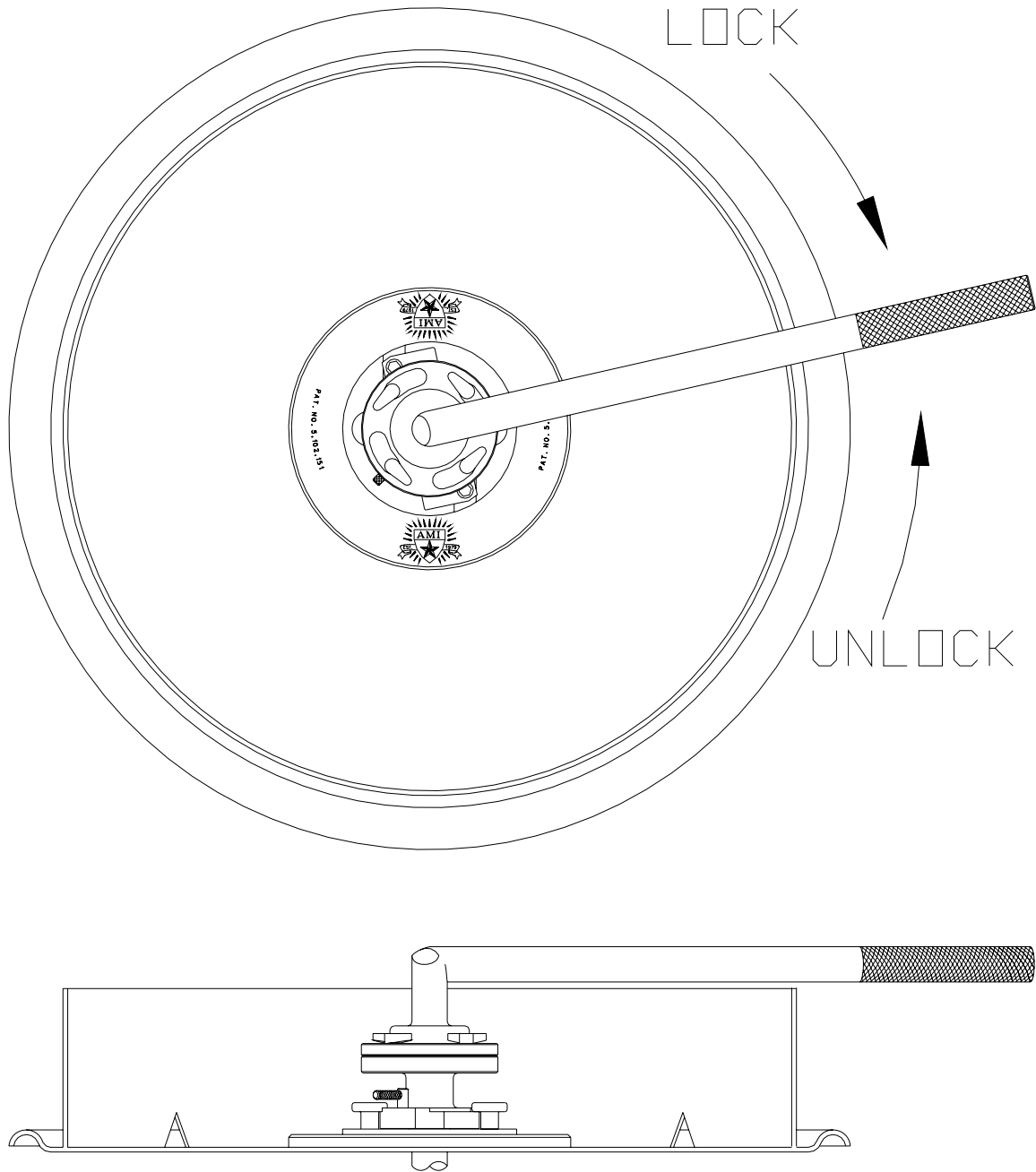

FIGURE 3